

DO NOT OPEN THIS TEST BOOKLET UNTIL YOU ARE ASKED TO DO SO

Test Booklet Series

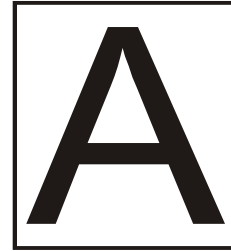

TEST BOOKLET

Electronics&Communication- Paper-I

Time Allowed: Two Hours

Maximum Marks: 200

INSTRUCTIONS

1. IMMEDIATELY AFTER THE COMMENCEMENT OF THE EXAMINATION YOU SHOULD CHECK THAT THIS TEST BOOKLET DOES NOT HAVE ANY UNPRINTED OR TORN OR MISSING PAGES OR ITEMS ETC. IF SO, GET IT REPLACED BY A COMPLETE TEST BOOKLET.
2. ENCODE CLEARLY THE TEST BOOKLET SERIES **A, B, C, OR D** AS THE CASE MAY BE IN THE APPROPRIATE PLACE IN THE ANSWER SHEET.
3. You have to enter your Roll Number on the Test Booklet in the Box provided alongside.
DO NOT write *anything else* on the Test Booklet.
4. This Test Booklet contains 120 items (questions). Each item comprises four responses (answers). You will select the response which you want to mark on the Answer Sheet. In case you feel that there is more than one correct response, mark the response which you consider the best. In any case, choose **ONLY ONE** response for each item.
5. You have to mark all your responses **ONLY** on the separate Answer Sheet provided. See directions in the Answer Sheet.
6. All items carry equal marks.
7. Before you proceed to mark in the Answer Sheet the response to various items in the Test Booklet, you have to fill in some particulars in the Answer Sheet as per instructions sent to you with your Admission Certificate.
8. After you have completed filling in all your responses on the Answer Sheet and the examination has concluded, you should hand over to the Invigilator **only the Answer Sheet**. You are permitted to take away with you the Test Booklet.
9. Sheets for rough work are appended in the Test Booklet at the end.
10. **Penalty for wrong answers:**
THERE WILL BE PENALTY FOR WRONG ANSWERS MARKED BY A CANDIDATE IN THE OBJECTIVE TYPE QUESTION PAPERS.
 - (i) There are four alternatives for the answer to every question. For each question for which a wrong answer has been given by the candidate, **one-third (0.33)** of the marks assigned to that question will be deducted as penalty.
 - (ii) If a candidate gives more than one answer, it will be treated as a **wrong answer** even if one of the given answers happens to be correct and there will be same penalty as above to that question.
 - (iii) If a question is left blank, i.e., no answer is given by the candidate, there will be no penalty for that question

DO NOT OPEN THIS TEST BOOKLET UNTIL YOU ARE ASKED TO DO SO

1. For smooth and reliable operation of an amplifier using BJT, it is necessary that the circuit must be properly designed from the point of view of bias stabilization, because
 1. Reverse saturation current I_{CO} increases with rise in temperature.
 2. V_{BE} decreases with rise in temperature.
 3. h_{FE} or β changes with change of temperature and replacement of the transistor.
 4. h_{FE} or β changes with change in collector supply voltage.

(a) 1, 2 and 3 only (b) 1, 2 and 4 only (c) 2, 3 and 4 only (d) 1, 2, 3 and 4
2. Intense magnetic field may be produced in a coil by using a
 - (a) Normal metal with a large number of turns and sending a large current
 - (b) Type-I superconductor with a large number of turns and sending a large current
 - (c) Type-II superconductor with a large number of turns and sending a large current
 - (d) Type-II superconductor with a large number of turns but limiting the current density below a critical value
3. The unit cell of a certain type of crystal is defined by three vectors \bar{a}, \bar{b} and \bar{c} . The vectors are mutually perpendicular, but $a \neq b \neq c$. The crystal structure is
 - (a) Triclinic (b) Tetragonal (c) Orthorhombic (d) Monoclinic
4. Biasing is used in transition amplifiers to
 1. Stabilize the operating point against temperature variations.
 2. Place the operating point in the linear region of the characteristics.
 3. Make α , β and I_{CO} of the transistor independent of temperature variations.
 4. Reduce distortion and increase dynamic range.

(a) 1, 2, 3 and 4 (b) 1, 2 and 4 only (c) 1, 2 and 3 only (d) 2, 3 and 4 only
5. The resistivity of a metal is a function of temperature because
 - (a) The electron density varies with temperature
 - (b) The electron gas density varies with temperature
 - (c) The lattices vibration increases with temperature
 - (d) Collision of electrons increases as temperature increases
6. An intrinsic semiconductor has the following properties :
 1. Its electron concentration equals its hole concentration.
 2. Its carrier density increases with temperature.
 3. Its conductivity decreases with temperature.

(a) 1, 2 and 3 (b) 2 and 3 only (c) 1 and 3 only (d) 1 and 2 only
7. A 'hole' in a semiconductor has
 1. Positive charge equal to the electron charge.
 2. Positive mass equal to the mass of the electron.
 3. An 'effective mass' greater than the effective mass of electron.
 4. Negative mass and positive charge equal to the charge in nucleus.

(a) 1, 2, 3 and 4 (b) 1 and 3 only (c) 2 and 4 only (d) 3 and 4 only
8. A CE amplifier has an unbypassed emitter resistance of $0.5 \text{ k}\Omega$ and a collector load of $5 \text{ k}\Omega$. The β of the transistor is 100 and it is operating at 1 mA. The voltage gain of the stage at mid band will be of the order of

- (a) 200 (b) 100 (c) 10 (d) 50
9. A common emitter transistor amplifier has a collector load of 10 kΩ. If its $h_{fe} = 100$ kΩ and $h_{ie} = 2$ kΩ ($h_{re} = h_{oe} \approx 0$), the voltage amplification of the amplifier is nearly equal to
 (a) 500 (b) 200 (c) 100 (d) 50
10. The free electrons in a metal follow the kinetic theory of gases and the following statements are made about their properties:
- The velocity of all the electrons is equal.
 - The electrons have a velocity distribution ranging from zero to infinity.
 - The average velocity of electron gas is proportional to \sqrt{T} (T = temperature).
 - The maximum velocity of electrons is proportional to T.
- Which of these statements are correct
 (a) 1, 2, 3 and 4 (b) 1 and 3 only (c) 2 and 3 only (d) 3 and 4 only
11. Using transistors,
- Class-A power amplifier has a minimum efficiency of 50%.
 - Class-B push-pull power amplifier gives rise to crossover distortion.
 - Class-AB push-pull power amplifier has higher efficiency than Class-B push-pull amplifier.
 - Class-C power amplifier is generally used with tuned load for RF amplification.
- (a) 1, 2, 3 and 4 (b) 2 and 4 only (c) 3 and 4 only (d) 1 and 2 only
12. A material shows spontaneous magnetization. This is due to
- Weiss molecular field.
 - Cooperative effect among dipoles.
 - Cooperative effect among domains.
 - Absence of applied magnetic field.
- (a) 1, 2, 3 and 4 (b) 2, 3 and 4 only (c) 1, 2 and 3 only (d) 1, 2 and 4 only
13. Materials in which the permanent dipoles interact with each other so heavily that they tend to align parallel to each other are called
 (a) Ferromagnetic (b) Ferrimagnetic (c) Paramagnetic (d) Anti-ferromagnetic
14. A type I superconductor is
- A conductor of infinite conductivity at all temperatures.
 - A conductor with very large conductivity below a critical temperature.
 - A material showing susceptibility = -1 below critical temperature.
 - A perfect conductor having conductivity drastically reduced by a critical current.
- (a) 1, 2 and 3 only (b) 2, 3 and 4 only (c) 1, 2 and 4 only (d) 1, 2, 3 and 4
15. In an RC coupled transistor amplifier
- Low-frequency response is determined by coupling capacitors.
 - High-frequency response is determined by junction capacitances.
 - Mid-frequency response is determined by both coupling and junction capacitances.
- (a) 1 and 2 only (b) 1 and 3 only (c) 2 and 3 only (d) 1, 2 and 3
16. Ti is diffused into a well defined region of LiNbO₃ crystal. The following effects are expected :
- An optical waveguide is formed in the region containing Ti.
 - Ti containing region has a larger refractive index than in undoped region.
 - Ti containing region has a lower refractive index than in undoped region.
- (a) 1, 2 and 3 (b) 1 and 3 only (c) 1 and 2 only (d) 2 and 3 only

17.

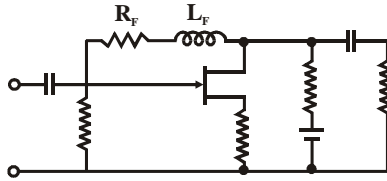

The inductance L_F and resistance R_F in the above circuit is used for

- (a) Low frequency compensation only
- (b) High frequency compensation only
- (c) Both low frequency and high frequency compensation
- (d) Increasing mid frequency gain without affecting the cut off frequencies

18.

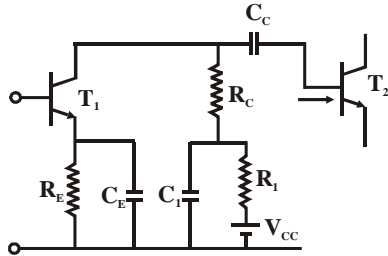

In the above circuit the optimum low frequency compensation is obtained when

- (a) $C_1 R_1 = R_E C_E$
- (b) $C_1 R_1 = C_C R_i$
- (c) $C_1 (R_C \parallel R_1) = C_C R_i$
- (d) $C_1 (R_C \parallel R_1) = R_E C_E$

19.

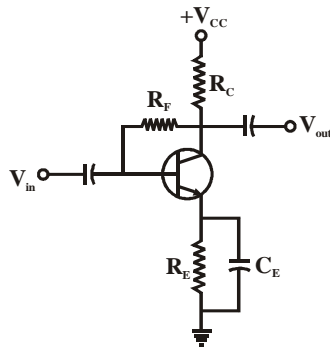

The amplifier circuit shown in the figure is an example of

- (a) Voltage series feedback
- (b) Voltage shunt feedback
- (c) Current series feedback
- (d) Current shunt feedback

20.

The peak output of tuned amplifier is at 6 MHz and has quality factor of 60. The bandwidth and 3 dB frequencies shall be

- (a) 100 MHz, 6.05 MHz and 5.95 MHz
- (b) 6 MHz, 9 MHz and 3 MHz
- (c) 600 kHz, 6.6 MHz and 5.4 MHz
- (d) 100 kHz, 6.05 MHz and 5.95 MHz

21.

On applying an electric field of intensity 10 V/cm across a semiconductor at a certain temperature the average drift velocity of free electrons is measured to be 70 m/s. Then the electron mobility is

- (a) $7 \times 10^4 \text{ cm}^2/\text{Vs}$
- (b) $700 \text{ cm}^2/\text{Vs}$
- (c) $7 \text{ m}^2/\text{Va}$
- (d) $700 \text{ cm}/\text{Vs}$

22.

Consider the following statements with regard to semiconductors :

1. In n type material free electron concentration is nearly equal to density of donor atoms.
2. 1 part in 10^8 donor type impurity added to Ge improves its conductivity at 30°C by a factor 12.
3. Phosphorus is an example of n type impurity.
4. Conductivity of Si is more sensitive to temperature than Ge.

Which of these statements are correct ?

- (a) 1, 2 and 3 only (b) 1, 3 and 4 only (c) 2 and 4 only (d) 1, 2, 3 and 4
23. The diffusion constant for holes in silicon is $13 \text{ cm}^2/\text{s}$. What is the diffusion current if the gradient of the hole concentration $\frac{dP}{dX} = -2 \times 10^{14}$ holes per cm^3 per cm ?
 (a) -0.416 mA (b) $-3.2 \times 10^{-5} \text{ A}$ (c) $32 \mu\text{A}$ (d) 0.416 mA
24. Given that at room temperature, the volt equivalent of temperature $V_T = 26 \text{ mV}$, hole mobility $\mu_p = 500 \text{ cm}^2/\text{Vs}$ and the life time of holes is 130 ns , in a sample of n-type silicon bar that is exposed to radiation at one end at low-injection level, what is the diffusion length of holes ?
 (a) 1300 microns (b) 100 Armstrongs (c) 169 microns (d) 100 microns
25. The function $(A \oplus B)$ is to be realized using only 2-input NAND gates. The minimum number of 2-input NAND gates required for such a realization is
 (a) 3 (b) 4 (c) 5 (d) 6

26.

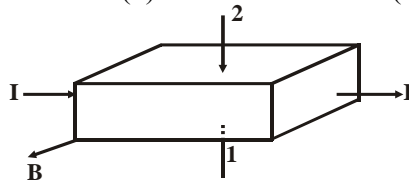

Consider a semiconductor carrying current and placed in a transverse magnetic field B , as shown above. The measured potential across 1 and 2 surfaces is positive at 2. What is the type of material ?

- (a) Intrinsic Si material (b) n-type semiconductor material
 (c) p-type semiconductor material (d) No such conclusion can be drawn
27. A 700 mW maximum power dissipation diode at 25°C has $5 \text{ mW}/^\circ\text{C}$ de-rating factor. If the forward voltage drop remains constant at 0.7 V , the maximum forward current at 65°C is
 (a) 700 mA (b) 714 mA (c) 1 A (d) 1 mA

28.

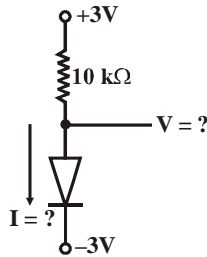

For the circuit shown above, using ideal diode, the values of voltage and current are

- (a) -3 V and 0.6 mA (b) 3 V and 0.0 mA (c) 3 V and 0.6 mA (d) -3 V and 0.0 mA
29. Consider the following statements :
- The radiation falling on a photodiode is primarily a minority carrier injector.
 - The short-circuit current of a reverse biased photodiode under illumination varies exponentially with light intensity.
 - The photovoltaic emf of an open-circuited photodiode varies logarithmically with the light-generated short-circuit current.
 - The spectral response of a photodiode does not depend upon the frequency of the incident light.

Which of these statements are correct ?

- (a) 1, 2, 3 and 4 (b) 3 and 4 only (c) 1 and 2 only (d) 1 and 3 only

30. Match List I with List II and select the correct answer using the code given below the lists :

List I				List II					
A.	At peak point			1.	Low tunneling current				
B.	At valley point			2.	Zero tunneling current				
C.	Reverse bias region			3.	High diffusion current				
D.	Beyond valley point			4.	High tunneling current				
Code :	A	B	C	D	A	B	C	D	
(a)	3	2	4	1	(b)	1	2	4	3
(c)	3	4	2	1	(d)	1	4	2	3

31. A half-wave rectifier has an input voltage of 240 V rms. If the step-down transformer has a turns ratio of 8 : 1, what is the peak load voltage ? Ignore diode drop.

- (a) 27.5 V (b) 86.5 V (c) 30.0 V (d) 42.5 V

32. Consider the following statements :

- The efficiency of a light emitting diode (LED) decreases with the injected current.
- The efficiency of a LED increases with a decrease in temperature.
- The light emitted is concentrated near the junction because most of the carriers the junctions because most of the carriers are within a diffusion length of the junction.
- Light is emitted in a LED when electrons move from the valence band to the conduction band.

Which of these statements are correct

- (a) 1, 2, 3 and 4 (b) 1 and 2 only (c) 3 and 4 only (d) 2 and 3 only

33. The collector and emitter current levels for a transistor with common base dc current gain of 0.99 and base current of 20 μ A are respectively

- (a) 2 mA and 2.98 mA (b) 1.98 μ A and 2 mA
(c) 1.98 mA and 2 mA (d) 2 mA and 1.98 μ A

34. The difference between PLA and ROM is

- (a) PLA is sequential, ROM is combinational (b) PLA is combinational, ROM is sequential
(c) PLA economizes on the number of min-terms to implement Boolean functions
(d) PLA has fixed AND array, ROM has fixed OR array

35. Consider the following statements :

- In a silicon controlled rectifier (SCR), if the cathode gate is reverse-biased, then the SCR cannot fire at all.
- The turn-on time of an SCR increases with temperature.
- After an SCR is turned on, it can be made to turn off again by reverse biasing the gate.
- Gate recovery time is the minimum time that the anode voltage must be maintained below holding voltage V_H to turn off the SCR.

Which of these statements are correct ?

- (a) 1, 2, 3 and 4 (b) 1 and 2 only (c) 2 and 4 only (d) 3 and 4 only

36. Which one of the following statements is correct about SCR ?

- (a) SCR is constructed using an npn and pnp transistor by connecting base of one transistor to collector of the other transistor.

- (b) To switch off an SCR, gate current must be reduced below certain threshold value.
 (c) Higher levels of gate currents in SCR cause it to conduct at lower anode-to-cathode voltages.
 (d) The higher the gate current in SCR, the higher the holding current to switch off.
37. The p-type epitaxial layer grown over an n-type substrate for fabricating a bipolar transistor will function as
 (a) The collector of a p-n-p transistor (b) The base of an n-p-n transistor
 (c) The emitter of a p-n-p transistor (d) The collector contact for a p-n-p transistor
38. The biasing of an IC BJT is done by the following biasing scheme :
 (a) Potential-divider biasing scheme (b) Fixed biasing scheme
 (c) Current mirror biasing scheme (d) Collector to base feedback biasing scheme
39. Consider the following statements about CMOS :
 1. CMOS logic inverter has maximum signal swing of 0 V to V_{DD} .
 2. The output signal swing is independent of exact value of aspect ratio and other device parameters.
 3. It is a fast switching device with wide noise margins.
 4. It has zero input resistance and infinite output resistance.
 Which of these statements are correct ?
 (a) 1, 2, 3 and 4 (b) 1, 2 and 4 only (c) 2, 3 and 4 only (d) 1, 2 and 3 only
40. Match List I with List II and select the correct answer using the code given below the lists :

List I	List II
A. LED	1. Electrical isolator
B. LCD	2. Forward biased
C. Opto couplers	3. Light reflectors / transmitters
D. Photodiode	4. Reverse biased

Code : A B C D	A B C D
(a) 4 1 3 2	(b) 2 1 3 4
(c) 4 3 1 2	(d) 2 3 1 4
41. Given a unity feedback system with $G(s) = \frac{K}{s(s+6)}$, the value of K for damping ratio of 0.75 is
 (a) 1 (b) 4 (c) 16 (d) 64
42. System is said to be marginally stable, if
 (a) Gain crossover frequency > Phase crossover frequency
 (b) Gain crossover frequency = Phase crossover frequency
 (c) Gain crossover frequency < Phase crossover frequency
 (d) Gain crossover frequency \neq Phase crossover frequency
43. System transformation function $H(z)$ for a discrete time LTI system expressed in state variable form with zero initial conditions is
 (a) $c(zI - A)^{-1}b + d$ (b) $c(zI - A)^{-1}$ (c) $(zI - A)^{-1}z$ (d) $(zI - A)^{-1}$
44. Unit step response of the system described by difference equation $y(n) + y(n-1) = x(n)$ is
 (a) $\frac{z^2}{(z+1)(z-1)}$ (b) $\frac{z}{(z+1)(z-1)}$ (c) $\frac{(z+1)}{(z-1)}$ (d) $\frac{z(z-1)}{(z+1)}$

45. Which one of the following relations is not correct ?

- (a) $f(t)\delta(t) = f(0)\delta(t)$ (b) $\int_{-\infty}^{\infty} f(t)\delta(\tau)d\tau = 1$
 (c) $\int_{-\infty}^{\infty} \delta(\tau)d(\tau) = 1$ (d) $f(t)\delta(t-\tau) = f(\tau)\delta(t-\tau)$

46. A family of constant N circles has the centre as

- (a) $X = 1$ and $Y = 2N$ (b) $X = -\frac{1}{4}$ and $Y = 4N$
 (c) $X = -\frac{1}{2}$ and $Y = \frac{1}{4N}$ (d) $X = -\frac{1}{2}$ and $Y = \frac{1}{2N}$

47.

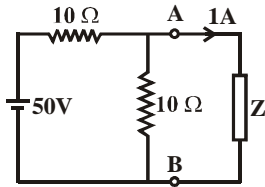

Consider the circuit shown above. The portion of the circuit left to the terminals AB can be replaced by

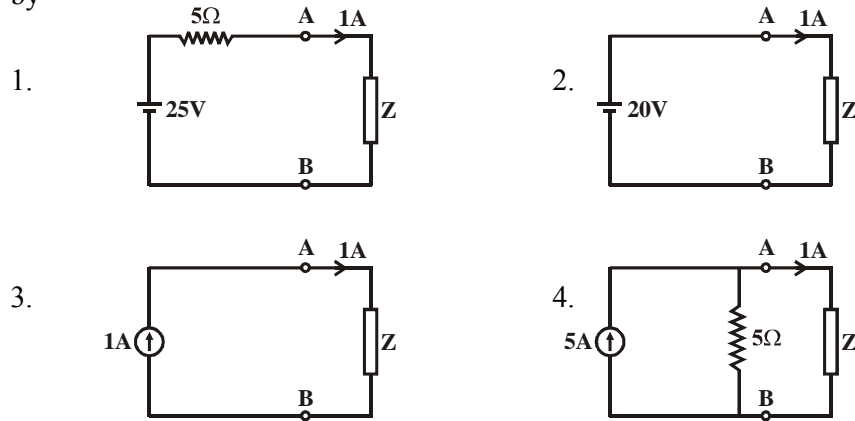

- (a) 1 and 2 only (b) 2 and 3 only (c) 1, 2 and 3 only (d) 1, 2, 3 and 4

48.

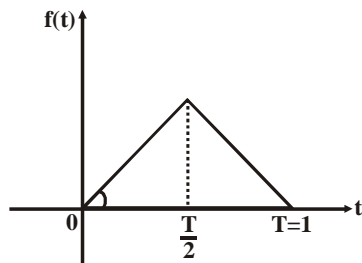

Laplace transform of the function $f(t)$ shown in the figure is

- (a) $\frac{2}{s^2}[1 - e^{-0.5s}]^2$ (b) $\frac{2}{s^2}[1 + e^{-0.5s}]^2$ (c) $\frac{2}{s^2}[1 - e^{0.5s}]^2$ (d) $\frac{2}{s^2}[1 + e^{0.5s}]^2$

49. Time constants of R-L and R-C circuits are respectively :

$R = 1 \Omega; \quad L = 1 \text{ H} \quad \text{and} \quad C = 1 \text{ F}$

- (a) 1 sec and 1 sec (b) 1 sec and 2 sec (c) 2 sec and 3 sec (d) 2 sec and 4 sec

50. Which one of the following gives the V – I characteristic of an ideal voltage source ?

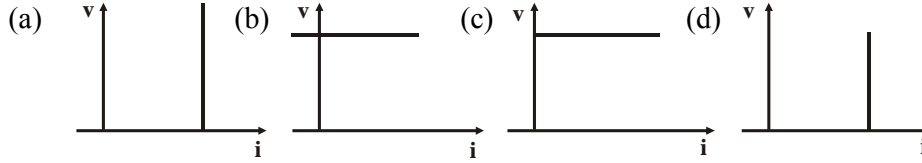

51.

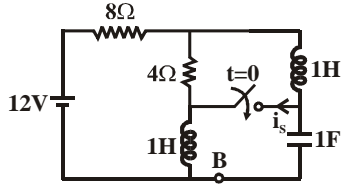

The circuit shown in the figure is in steady state before the switch is closed at $t = 0$. The current $i_s(0^+)$ through the switch is

- (a) $1/3$ A (b) $2/3$ A (c) 1 A (d) 0 A

52. Consider the following statements :

1. Voltage across a capacitor cannot change abruptly.
2. Voltage across an inductor cannot change abruptly.
3. Current through a capacitor cannot change abruptly.
4. Current through an inductor cannot change abruptly.

Which of these statements are correct ?

- (a) 1 and 2 only (b) 2 and 3 only (c) 3 and 4 only (d) 1 and 4 only

53. Match List I with List II and select the correct answer using the code given below the lists :

List I		List II	
A.	Superposition theorem	1.	Impedance matching in audio circuits
B.	Thevenin's theorem	2.	Linear bilateral networks
C.	Kirchhoff's voltage and current laws	3.	Large network in which currents in few elements to be determined
D.	Maximum power transfer theorem	4.	Currents and voltages in all branches of a network

Code :	A	B	C	D	A	B	C	D	
(a)	1	4	3	2	(b)	2	4	3	1
(c)	1	3	4	2	(d)	2	3	4	1

54.

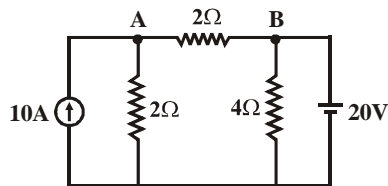

The current through the branch AB in the figure shown is

- (a) 10 A, from A to B (b) 10 A, from B to A (c) 0 (d) 20 A, from B to A

55.

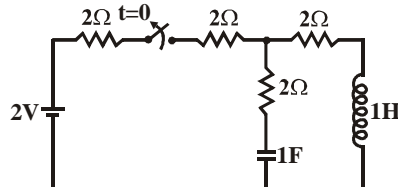

In the circuit shown, the switch is opened at $t = 0$. The circuit is

- (a) Critically damped (b) Under-damped (c) Over-damped (d) Undamped

56.

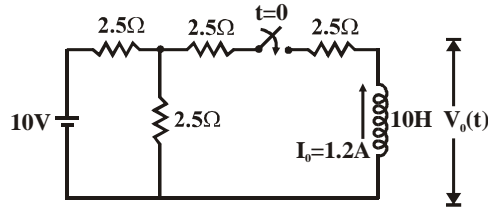

In the circuit shown, the initial current I_0 through the inductor is given in the figure. The initial value of the voltage across the inductor $V_0(0^+)$ is

- (a) 12.5 V (b) 5.0 V (c) 10.0 V (d) 0.0 V

57.

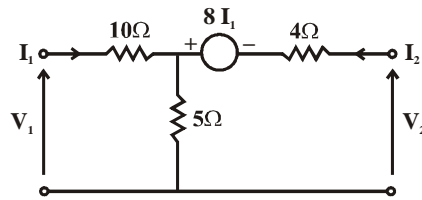

For the network shown in the figure, Y_{11} and Y_{12} are, respectively

- (a) $\frac{3}{50}$ mho and $-\frac{1}{30}$ mho (b) $\frac{3}{50}$ mho and $\frac{1}{30}$ mho
(c) $-\frac{3}{50}$ mho and $-\frac{1}{30}$ mho (d) $-\frac{3}{50}$ mho and $\frac{1}{30}$ mho

58.

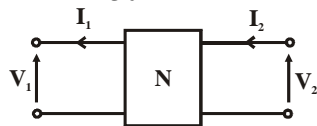

A two-port network satisfies the following relations :

$$4I_1 + 8I_2 = 2V_1$$

$$8I_1 + 16I_2 = V_2$$

1. The network is reciprocal 2. $Z_{11} = 4$ and $Z_{12} = 8$
3. $Z_{21} = 8$ and $Z_{22} = 16$ 4. $Z_{11} = 2$ and $Z_{12} = 4$

Which of these relations are correct ?

- (a) 1, 2, 3 and 4 (b) 2 and 3 only (c) 3 and 4 only (d) 1 and 2 only

59.

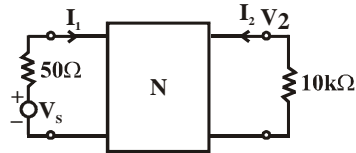

In the circuit shown, 2-port network N has $Z_{11} = 10^3 \Omega$, $Z_{12} = 10 \Omega$, $Z_{21} = -10^6 \Omega$ and $Z_{22} = 10^4 \Omega$.

The current gain $\frac{I_2}{I_1}$ is

- (a) -50 (b) +50 (c) +20 (d) -20

60.

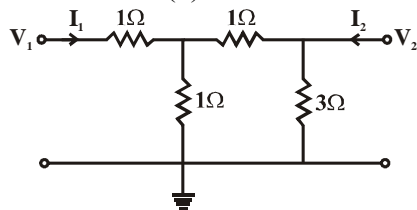

In the 2-port network shown in the figure, the value of Y_{12} is

- (a) $-\frac{1}{3}$ mho (b) $+\frac{1}{3}$ mho (c) -3 mho (d) $+3$ mho

61. For a network transfer function $H(s) = \frac{P(s)}{Q(s)}$, where $P(s)$ and $Q(s)$ are polynomials in S ,

1. The degree of $P(s)$ and $Q(s)$ are same.
2. The degree of $P(s)$ is always greater than the degree of $Q(s)$.
3. The degree of $P(s)$ is independent of the degree of $Q(s)$.
4. The maximum degree of $P(s)$ and $Q(s)$ differ at most by one.

Which of these statements are correct ?

- (a) 1, 2, 3 and 4 (b) 1, 2 and 3 only (c) 1, 2 and 4 only (d) 2, 3 and 4 only

62.

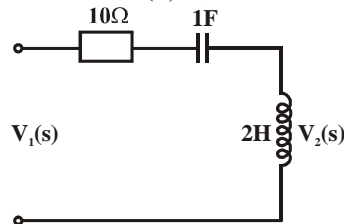

The driving point impedance of the network shown in figure is

- (a) $10 + 2s$ (b) $10 + 2s + \frac{1}{s}$ (c) 10 (d) $\frac{1}{s}$

63. 1.

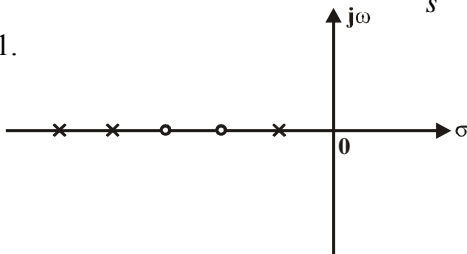

2.

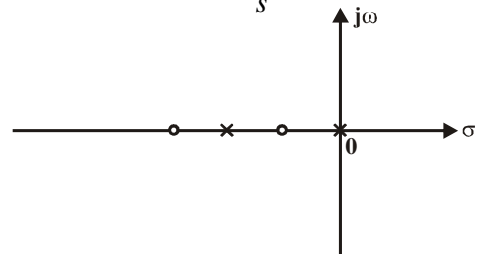

3.

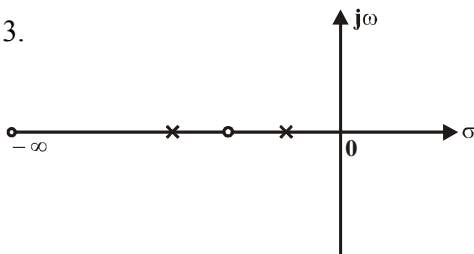

4.

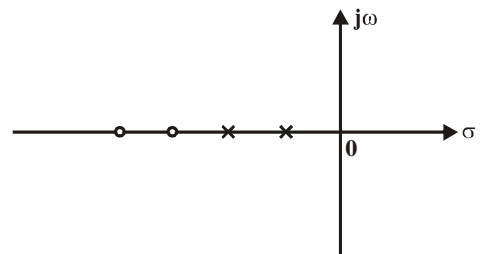

The valid pole-zero patterns for an RL driving point impedance function, are

- (a) 1 and 2 only (b) 2 and 3 only (c) 3 and 4 only (d) 1, 2, 3 and 4

64. The Foster I realization of the driving point impedance function $Z(s) = \frac{3(s^2 + 1)(s^2 + 49)}{s(s^2 + 9)}$ is shown

below.

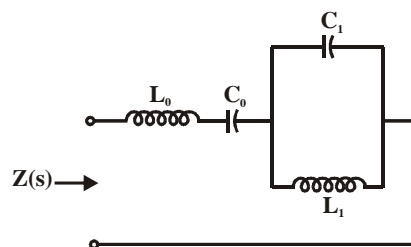

The values of L_0 and C_0 are, respectively,

- (a) $3\text{ H and } \frac{49}{3}\text{ F}$ (b) $3\text{ H and } \frac{3}{49}\text{ F}$ (c) $\frac{1}{3}\text{ H and } \frac{3}{49}\text{ F}$ (d) $\frac{1}{3}\text{ H and } \frac{49}{3}\text{ F}$

65. Consider the following statements :

1. Poles and zeros are simple and interlace.
2. Residues at the poles on the imaginary axis are real.
3. $Z_{RC}(0) > Z_{RC}(\infty)$.
4. The slopes of the reactance curves are positive.

Which of these properties are correct for an RC driving point impedance $Z_{RC}(s)$?

- (a) 1 and 3 only (b) 2 and 4 only (c) 3 and 4 only (d) 1, 2, 3 and 4

66.

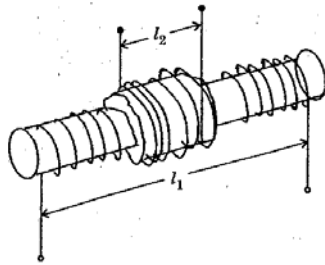

Two coils N_1 and N_2 turns are wound concentrically on a straight cylindrical core of radius r and permeability μ . The windings have length l_1 and l_2 respectively as shown in figure. The mutual inductance will be

1. Proportional to N_1N_2 .
2. Proportional to μ .
3. Inversely proportional to l_1 .
4. Inversely proportional to r^2 .

Which of these statements are correct ?

- (a) 1, 2, 3 and 4 (b) 2, 3 and 4 only (c) 1, 2 and 3 only (d) 1, 3 and 4 only

67. A varying magnetic flux linking a coil is given by $\Phi = \frac{1}{3}\lambda t^3$. If at time $t = 3$ s, the emf induced is 9

V, then the value of λ is

- (a) Zero (b) 1 Wb/s^2 (c) -1 Wb/s^2 (d) 9 Wb/s^2

68. If the potential, $V = 4x + 2$ volts, the electric field is

- (a) 6 V/m (b) 2 V/m (c) 4 V/m (d) $-4\bar{a}_x\text{ V/m}$

69. If the current element represented $4 \times 10^{-4}\bar{a}_y$ Amp-m is placed in a magnetic field of $\bar{H} = \frac{5\bar{a}_x}{\mu}$ A/m,

the force on the current element is

- (a) $-2.0\bar{a}_z\text{ mN}$ (b) $2.0\bar{a}_z\text{ mN}$ (c) $-2.0\bar{a}_z\text{ N}$ (d) $2.0\bar{a}_z\text{ N}$

70. Match List I with List II and select the correct answer using the code given below the lists :

- | List I | List II |
|------------------|---------------------|
| A. MMF | 1. Conductivity |
| B. Magnetic flux | 2. Electric current |
| C. Reluctance | 3. EMF |
| D. Permeability | 4. Resistance |

- | | | | | | | | | | |
|--------|---|---|---|---|-----|---|---|---|---|
| Code : | A | B | C | D | A | B | C | D | |
| (a) | 3 | 4 | 2 | 1 | (b) | 1 | 2 | 4 | 3 |
| (c) | 3 | 2 | 4 | 1 | (d) | 1 | 4 | 2 | 3 |

71. Given that the electric flux density $D = z\rho(\cos^2 \Phi)\bar{a}_z \text{ C/m}^2$.

The charge density at point $(1, \pi/4, 3)$ is

- (a) 3 (b) 1 (c) 0.5 (d) $0.5 \bar{a}_z$

72.

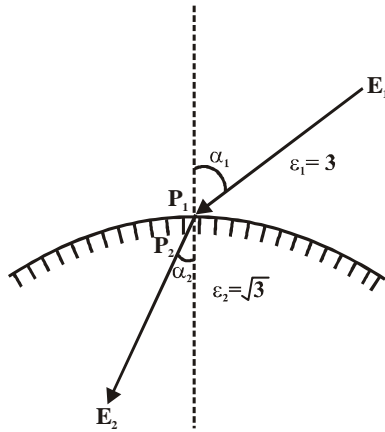

Two dielectric media with permittivities 3 and $\sqrt{3}$ are separated by a charge-free boundary as shown in figure. The electric field intensity in medium 1 at point P_1 has magnitude E_1 and makes an angle $\alpha_1 = 60^\circ$ with the normal. The direction of the electric field intensity at point P_2 , α_2 is

- (a) $\sin^{-1}\left(\frac{\sqrt{3}E_1}{2}\right)$ (b) 45° (c) $\cos^{-1}\left(\frac{\sqrt{3}E_1}{2}\right)$ (d) 30°

73. For no reflection condition, a vertically polarized wave should be incident at the interface between two dielectrics having $\epsilon_1 = 4$ and $\epsilon_2 = 9$, with an incident angle of

- (a) $\tan^{-1}\left(\frac{9}{4}\right)$ (b) $\tan^{-1}\left(\frac{3}{2}\right)$ (c) $\tan^{-1}\left(\frac{2}{3}\right)$ (d) $\tan^{-1}\left(\frac{4}{9}\right)$

74. Assuming that each loop is stationary and time varying magnetic field \bar{B} , induces current I, which of the configuration in the figure are correct ?

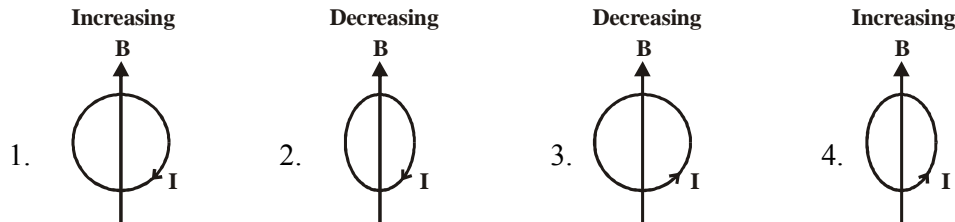

- (a) 1, 2, 3 and 4 (b) 1 and 3 only (c) 2 and 4 only (d) 3 and 4 only

75. The electric field component of a wave in free space is given by $\bar{E} = 10 \cos(10^7 t + kZ)\bar{a}_y \text{ V/m}$.

Following is a list of possible inferences :

- | | |
|---------------------------------------|---|
| 1. Wave propagates along \bar{a}_y | 2. Wavelength $\lambda = 188.5 \text{ m}$ |
| 3. Wave amplitude is 10 V/m | 4. Wave number = 0.33 rad/m |
| 5. Wave attenuates as it travels | |

Which of these inferences can be drawn from \bar{E} ?

- (a) 1, 2, 3, 4 and 5 (b) 2 and 3 only (c) 3 and 4 only (d) 4 and 5 only

76. An electromagnetic wave of frequency 3 MHz passes from vacuum into a dielectric medium with permittivity $\epsilon = 4.0$. Then

- (a) Wavelength is doubled and the frequency remains unchanged
 (b) Wavelength is doubled and the frequency becomes half
 (c) Wavelength is halved and the frequency remains unchanged
 (d) Both the wavelength and frequency remain unchanged

77.

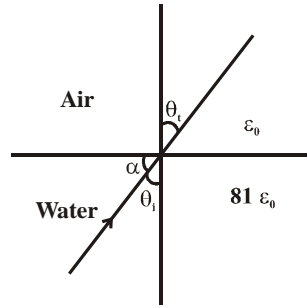

A plane wave is generated under water ($\epsilon = 81 \epsilon_0$ and $\mu = \mu_0$). The wave is parallel polarized. At the interface between water and air, the angle α for which there is no reflection is

- (a) 83.88° (b) 83.66° (c) 84.86° (d) 84.08°

78. The characteristic impedance of TV receiving antenna cable is 300Ω . If the conductors are made of copper separated by air and are 1 mm thick, what is the phase velocity and phase constant when receiving VHF channel 3 (63 MHz) and VHF 69 (803 MHz) ?

- (a) 1.32 rad/m and 17.82 rad/m (b) 1.52 rad/m and 16.82 rad/m
 (c) 1.52 rad/m and 17.82 rad/m (d) 1.32 rad/m and 16.82 rad/m

79. If maximum and minimum voltages on a transmission line are 4 V and 2 V respectively, VSWR is

- (a) 0.5 (b) 2 (c) 1 (d) 8

80. An ideal lossless transmission line of $Z_0 = 60 \Omega$ is connected to unknown Z_L . If $SWR = 4$, find Z_L .

- (a) 240Ω (b) 480Ω (c) 120Ω (d) 100Ω

81. Loading of a cable is done to

1. Increase its inductance 2. Increase its leakage resistance
 3. Decrease its capacitance 4. Achieve distortionless condition

- (a) 1, 2, 3 and 4 (b) 1 and 2 only (c) 2 and 3 only (d) 1 and 4 only

82. Consider the following statements about the Smith chart :

1. A complete revolution (360°) around the Smith chart represents a distance of half wavelength on the line.
 2. Clockwise movement on the chart is regarded a moving toward the generator.
 3. Although three scales around the periphery of Smith chart are used, but only one scale can be sufficient.
 4. Smith chart cannot be used as admittance chart.

Which of these statements are correct ?

- (a) 1, 2, 3 and 4 (b) 1, 2 and 4 only (c) 2, 3 and 4 only (d) 1, 2 and 3 only

83. Consider the following statements :

1. The antennas radiate energy.

2. An antenna is a transition device, or transducer between a guided wave and a free space wave or vice versa.
3. The resonators and transmission lines store energy.
4. An antenna converts electromagnetic signal to currents or vice versa.

Which of these statements are correct ?

- (a) 1, 2 and 4 only (b) 1, 2 and 3 only (c) 2, 3 and 4 only (d) 1, 2, 3 and 4

84. An antenna can be modeled as an electric dipole of length 5 m at 3 MHz. Find the reduction resistance of the antenna assuming uniform current over the length.

- (a) 2 Ω (b) 1 Ω (c) 4 Ω (d) 0.5 Ω

85. Match List I with List II and select the correct answer using the code given below the lists :

List I		List II
A. Two isotropes half wavelength apart fed in phase	1.	
B. Two isotropes quarter wavelength apart 90° phase shift	2.	
C. Two isotropes quarter wavelength apart fed in phase	3.	
Code : A B C		A B C
(a) 1 3 2	(b)	2 3 1
(c) 1 2 3	(d)	2 1 3

86. An antenna located on the surface of a flat earth transmits an average power of 200 kW. Assuming that all the power is radiated uniformly over the surface of a hemisphere with the antenna at the center, the time average Poynting vector at 50 km is

- (a) Zero (b) $\frac{2}{\pi} \bar{a}_r$ W/m² (c) $\frac{40}{\pi} \mu$ W/m² (d) $\frac{40}{\pi} \bar{a}_r \mu$ W/m²

87. Which one of the following meters has maximum loading effect on the circuit under measurement ?

- (a) 1000 Ω / volt (b) 100 Ω / volt (c) 1 MΩ / volt (d) 10 MΩ / volt

88. A second order pressure transducer has a natural frequency of 30 rad/sec, static sensitivity K = 1.0 μV/Pa. When a step pressure input of 8×10^5 N/m² is applied, damped frequency of 29.85 rad/sec is observed. The damping ratio of the transducer is

- (a) Zero (b) 0.707 (c) 1.0 (d) 0.1

89. A voltmeter with an internal resistance of 200 kΩ when connected across an unknown resistance reads 250 V. The milliammeter internal resistance ≈ 0 connected in series with the above combination reads 10 mA. The actual value of the unknown resistance is

- (a) 25 kΩ (b) 200 kΩ (c) 28.56 kΩ (d) 20 kΩ

- 90.

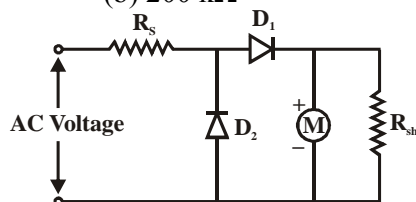

The figure shows the circuit of a rectifier type voltmeter. The diode D_2

1. Does not allow any current to flow through the meter during negative half cycle.
2. Does not allow reverse leakage current to flow through the meter during negative half cycle.
3. Short circuits the meter during negative half cycle.

Which of these statements are correct ?

- (a) 1 and 2 only (b) 2 and 3 only (c) 1 and 3 only (d) 1, 2 and 3
91. A good S/H circuit should have
1. High input impedance
 2. High output impedance
 3. Low input impedance
 4. Low output impedance
- (a) 1 and 2 only (b) 2 and 3 only (c) 3 and 4 only (d) 1 and 4 only
92. When a sinusoidal signal of 220 V, 50 Hz produces on CRO a vertical deflection of 2 cm at a particular setting of the vertical gain control, what would be the value of the voltage to be applied to produce a deflection of 3 cm for the same vertical gain ?
- (a) 330 V (b) 110 V (c) 220 V (d) 55 V
93. A 1000 Hz sinusoidal voltage is connected to both X and Y inputs of a CRO. Which of the following waveforms is seen on CRO ?
- (a) Sine wave (b) Circle (c) Ellipse (d) Straight line
94. A dual slope Analog to Digital converter
1. Responds very fast.
 2. Has better accuracy.
 3. Requires an accurate and stable dc source.
 4. Requires a buffer at the input side.
- (a) 1 is not correct (b) 2 and 3 are correct
(c) 3 and 4 are correct (d) 1, 2, 3 and 4 are correct
95. A digital voltmeter has $4\frac{1}{2}$ digit display. The 1 V range can read up to
- (a) 1.0000 V (b) 1.1111 V (c) 0.9999 V (d) 1.9999 V
96. Consider the following statements for an N-bit DACs :
1. R-2R ladder type is based on dual slope integration.
 2. R-2R requires resistors of large spread in values.
 3. R-2R requires roughly 2N resistors.
 4. R-2R requires roughly N number of resistors.
- Which of these statements are correct ?
- (a) 3 only (b) 1 only (c) 1 and 3 (d) 2 and 4
97. A 10 bit A/D converter is used in a DMM. The maximum peak to ripple voltage allowed in the dc supply voltage for a measurement range of 0 to 5 V is
- (a) 100 mV (b) 25 mV (c) 5 mV (d) 50 mV
98. Match List I with List II and select the correct answer using the code given below the lists :
- | | |
|--|---|
| <p>Lit I</p> <p>A. Hot wire</p> <p>B. LVDT</p> <p>C. Piezoelectric</p> <p>D. Hall effect</p> | <p>List II</p> <p>1. Gas flow</p> <p>2. Displacement</p> <p>3. Current</p> <p>4. Acceleration</p> |
|--|---|

Code : A	B	C	D	A	B	C	D
(a) 1	4	2	3	(b) 3	4	2	1
(c) 1	2	4	3	(d) 3	2	4	1

99. Match List I with List II and select the correct answer using the code given below the lists :

List I				List II			
A.	Chromel-Alumel	1.	Long life and low thermal conductivity				
B.	Iron-Constantan	2.	Inexpensive and mechanically strong				
C.	Platinum-Rhodium	3.	Low sensitivity and high stability				
D.	Copper-Constantan	4.	Suitable for measurement below 0°C and high reliability				

Code : A	B	C	D	A	B	C	D
(a) 1	2	3	4	(b) 4	2	3	1
(c) 1	3	2	4	(d) 4	3	2	1

100. A platinum resistance thermometer has a resistance of 140.5 Ω at 100°C and 100.0 Ω at 0°C. When it is in contact with a hot gas, its resistance becomes 305.3 Ω. The temperature of the gas is (Assuming temperature coefficient of platinum is 0.004/°C) close to

(a) 300°C (b) 400°C (c) 500°C (d) 600°C

101. Optical Pyrometer is generally used to measure

(a) Low pressure (b) Low temperature (c) High temperature (d) High pressure

102. Match List I with List II and select the correct answer using the code given below the lists :

List I				List II			
A.	Ferrite	1.	Meissner effect				
B.	Superconductor	2.	Faraday effect				
C.	Quartz	3.	Hysteresis				
D.	Iron	4.	Piezoelectricity				

Code : A	B	C	D	A	B	C	D
(a) 3	1	4	2	(b) 2	1	4	3
(c) 3	4	1	2	(d) 2	4	1	3

103.

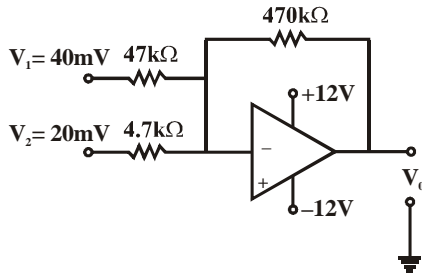

What is the output voltage for the above circuit ?

(a) - 4.8 V (b) + 1.2 V (c) - 2.4 V (d) + 2.4 V

104. Doping intrinsic Silicon with Arsenic as an impurity

- (a) Only increases the conductivity of Silicon by increasing the number of free electrons available
- (b) produces a semi-conductor in which the charge carriers are predominantly electrons but holes are also present
- (c) Produces a semi-conductor in which the charge carriers are predominantly holes but free electrons also present

(d) Produces a semi-conductor in which the charge carriers contain nearly equal number of electrons and holes

105. A dipole with a length of 1.5 m operates at 100 MHz while the other has a length of 15 m and operates at 10 MHz. The dipoles are fed with same current. The power radiated by the two antennas will be

- (a) The longer antenna will radiate 10 times more power than the shorter one
- (b) Both antennas radiate same power
- (c) Shorter antenna will radiate 10 times more power than the longer antenna
- (d) Longer antenna will radiate $\sqrt{10}$ times more power than the shorter antenna

Directions : Each of the next fifteen (15) items consists of two statements, one labelled as the 'Assertion (A)' and the other as 'Reason (R)'. You are to examine these two statements carefully and select the answers to these items using the codes given below :

Codes :

- (a) Both A and R are individually true and R is the correct explanation of A
- (b) Both A and R are individually true but R is not the correct explanation of A
- (c) A is true but R is false
- (d) A is false but R is true

106. Assertion (A) : The bias stability of a self bias amplifier circuit can be improved by increasing the values of both the base resistor (R_B) and the emitter resistor (R_E).

Reason (R) : The base resistor (R_B) provides the required voltage to the base terminal and the emitter resistor (R_E) provides negative feedback to the amplifier.

107. Assertion (A) : Thermal runaway occurs in FET circuits but it does not occur in BJT circuit.

Reason (R) : FET is a majority carrier device whereas BJT works based on the movement of both the majority and the minority carriers.

108. Assertion (A) : Good conductors do not show superconductivity.

Reason (R) : Electron-phonon interaction that leads to formation of Cooper pairs is weak in good conductors.

109. Assertion (A) : The typical common base output characteristics of a bipolar junction transistor remains almost parallel to the voltage axis, but shows very little increase in current with increase in the output voltage.

Reason (R) : The short circuit common base current gain (α) of a bipolar transistor increases with increase in the temperature.

110. Assertion (A) : The reverse saturation current approximately doubles for every 10°C temperature rise for both Si and Ge materials.

Reason (R) : At room temperature, the p-n junction voltage decreases by about 2.5 mV per °C with rise in temperature.

111. Assertion (A) : The resistance of a FET in non-conducting region is very high.

Reason (R) : The FET is a semiconductor device.

112. Assertion (A) : It is desired that the high frequency transistors should work at low collector currents for better high frequency performance.

Reason (R) : The diffusion capacitance is directly proportional to the emitter current.

113. Assertion (A) : In a transistor, it is desirable that the carriers contributing to emitter current in the active mode reach the collector terminal.
Reason (R) : The conductivity of the base in a transistor is made much smaller than the conductivity of the emitter.
114. Assertion (A) : Concentration of acceptor atoms in the region between isolation islands will be much higher p^+ than in the p type substrate in an integrated circuit.
Reason (R) : This is to prevent the depletion region of the reverse-biased isolation to substrate junction from extending into p^+ type material.
115. Assertion (A) : The power factor of an inductor is zero.
Reason (R) : The voltage across and current through the inductor are in quadrature.
116. Assertion (A) : When a series RLC circuit is in resonance the current flowing in the circuit is maximum.
Reason (R) : The inductive reactance and the capacitive reactance are equal in magnitude at resonance.
117. Assertion (A) : Under static conditions, the surface of conductor is an equipotential surface.
Reason (R) : The tangential component of electric field on conductor surface is zero.
118. Assertion (A) : For time varying field the relation $\vec{E} = -\nabla V$ is inadequate.
Reason (R) : Faraday's law states that for time varying field $\nabla \times \vec{E} = 0$.
119. Assertion (A) : The ratio of the tangential components of current density at two sides of an interface are equal to the conductivities.
Reason (R) : The normal component of current density is continuous.
120. Assertion (A) : Effect of frequency on calibration is also due to spurious capacitive currents.
Reason (R) : Spurious capacitive current does not occur in thermocouple instruments.