

DO NOT OPEN THIS TEST BOOKLET UNTIL YOU ARE ASKED TO DO SO

Test Booklet Series

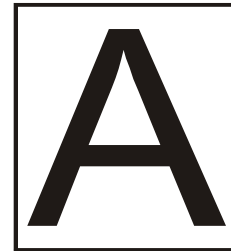

TEST BOOKLET

Electronics&Communication- Paper-II

Time Allowed: Two Hours

Maximum Marks: 200

INSTRUCTIONS

1. IMMEDIATELY AFTER THE COMMENCEMENT OF THE EXAMINATION YOU SHOULD CHECK THAT THIS TEST BOOKLET DOES NOT HAVE ANY UNPRINTED OR TORN OR MISSING PAGES OR ITEMS ETC. IF SO, GET IT REPLACED BY A COMPLETE TEST BOOKLET.
2. ENCODE CLEARLY THE TEST BOOKLET SERIES **A, B, C, OR D** AS THE CASE MAY BE IN THE APPROPRIATE PLACE IN THE ANSWER SHEET.
3. You have to enter your Roll Number on the Test Booklet in the Box provided alongside.
DO NOT write *anything else* on the Test Booklet.
4. This Test Booklet contains 120 items (questions). Each item comprises four responses (answers). You will select the response which you want to mark on the Answer Sheet. In case you feel that there is more than one correct response, mark the response which you consider the best. In any case, choose **ONLY ONE** response for each item.
5. You have to mark all your responses **ONLY** on the separate Answer Sheet provided. See directions in the Answer Sheet.
6. All items carry equal marks.
7. Before you proceed to mark in the Answer Sheet the response to various items in the Test Booklet, you have to fill in some particulars in the Answer Sheet as per instructions sent to you with your Admission Certificate.
8. After you have completed filling in all your responses on the Answer Sheet and the examination has concluded, you should hand over to the Invigilator **only the Answer Sheet**. You are permitted to take away with you the Test Booklet.
9. Sheets for rough work are appended in the Test Booklet at the end.
10. **Penalty for wrong answers:**
THERE WILL BE PENALTY FOR WRONG ANSWERS MARKED BY A CANDIDATE IN THE OBJECTIVE TYPE QUESTION PAPERS.
 - (i) There are four alternatives for the answer to every question. For each question for which a wrong answer has been given by the candidate, **one-third (0.33)** of the marks assigned to that question will be deducted as penalty.
 - (ii) If a candidate gives more than one answer, it will be treated as a **wrong answer** even if one of the given answers happens to be correct and there will be same penalty as above to that question.
 - (iii) If a question is left blank, i.e., no answer is given by the candidate, there will be no penalty for that question

DO NOT OPEN THIS TEST BOOKLET UNTIL YOU ARE ASKED TO DO SO

1. Consider the following statements :
 1. A Schmitt trigger circuit can be emitter-coupled bi-stable circuit.
 2. Schmitt trigger circuit exhibits hysteresis phenomenon.
 3. The output of a Schmitt trigger will be triangular if the input is square wave.
 Which of these statements are correct ?
 (a) 1, 2 and 3 (b) 1 and 2 only (c) 2 and 3 only (d) 1 and 3 only
2. In order to obtain repetitive pulses of unequal mark space durations one can use :
 1. A voltage comparator fed with a triangular wave signal and a dc voltage.
 2. An astable multi-vibrator.
 3. A mono-stable multi-vibrator fed with a square wave input.
 (a) 1 and 3 only (b) 1 and 2 only (c) 2 and 3 only (d) 1, 2 and 3
3. A small signal voltage amplifier in common emitter configuration was working satisfactorily. Suddenly its emitter-bypass capacitor (C_E) got disconnected. Its :
 1. Voltage gain will decrease 2. Voltage gain will increase
 3. Bandwidth will decrease 4. Bandwidth will increase
 (a) 1 and 4 only (b) 2 and 3 only (c) 3 and 4 only (d) 1, 2, 3 and 4
4. A series resonant circuit has a resistance of 47 ohms, inductance of 2 H and capacitance of 2 μ F with a supply voltage of 10 volts. The current through the circuit at resonance is :
 (a) 0.833 amp (b) 0.212 amp (c) 0.196 amp (d) 0 amp
5. Once an SCR is turned on, it remains so until the anode current goes below :
 (a) Trigger current (b) Break over current (c) Threshold current (d) Holding current
6. In a PLL :
 (a) Capture range = Lock range \neq Free running frequency
 (b) Capture range = Lock range = Free running frequency
 (c) Capture range > Lock range (d) Capture range < Lock range
7. The main advantage of active filter is that it can be realized without using :
 (a) Transistor (b) Capacitor (c) Resistor (d) Inductor

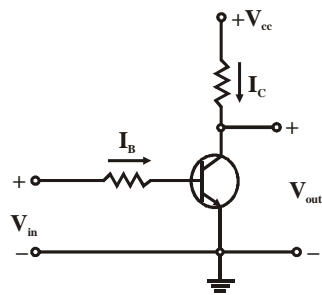

For the transistor circuit shown in the figure, when :

1. $V_{in} > 0$, transistor is OFF 2. $V_{in} \leq 0$ transistor is OFF
 3. $I_B > \frac{I_C}{h_{FE}}$ transistor is ON 4. $I_B \leq \frac{I_C}{h_{FE}}$ transistor is ON
- (a) 1, 2, 3 and 4 (b) 1 and 2 only (c) 2 and 3 only (d) 3 and 4 only
9. The logic function $f = \overline{x \cdot \bar{y}} + \overline{\bar{x} \cdot y}$ is the same as :
 (a) $f = (x + y) (\bar{x} + \bar{y})$ (b) $f = \overline{(\bar{x} + \bar{y}) (x + y)}$ (c) $f = \overline{(x \cdot y) (\bar{x} \cdot \bar{y})}$ (d) None of the above

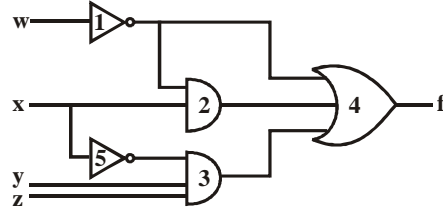

Which one of the following gates is redundant ?

- (a) Gate No. 1 (b) Gate No. 2 (c) Gate No. 3 (d) Gate No. 4

18. In standard TTL, the 'totem pole' refers to :

- (a) Multi-emitter input stage (b) The phase splitter
 (c) Open collector output stage (d) The output buffer

19.

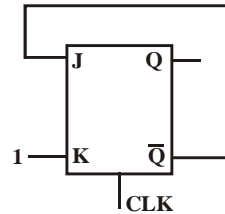

In a JK flip-flop we have $J = \bar{Q}$ and $K = 1$. Assuming the flip-flop was initially cleared and then clocked for 6 pulses, the sequence at the Q output will be :

- (a) 010000 (b) 011001 (c) 010010 (d) 010101

20. Which one of the following circuits converts a JK F/F to a T F/F ?

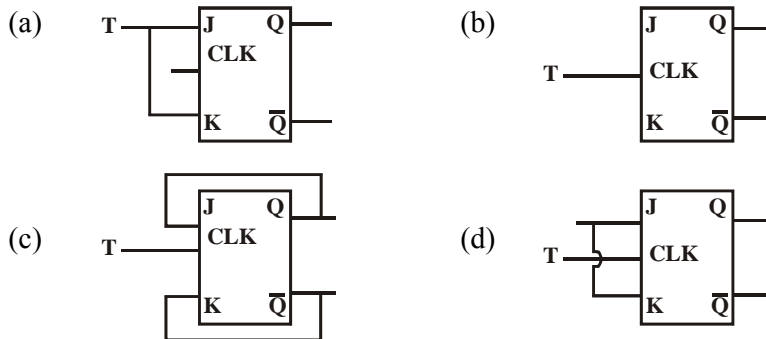

21. A 4-bit ripple counter consisting of flip-flops that each have a propagation delay of 12ns from clock to Q output. For the counter to recycle from 1111 to 0000, it takes a total of :

- (a) 12 ns (b) 25 ns (c) 48 ns (d) 26 ns

22. An eight-bit binary ripple UP counter with a modulus of 256 is holding the count 01111111. What will be the count after 135 clock pulses ?

- (a) 0000 0101 (b) 1111 1001 (c) 0000 0110 (d) 0000 0111

23.

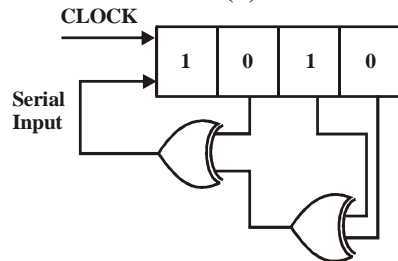

The shift register shown in the figure is initially loaded with the bit pattern 1010. Subsequently the shift register is clocked, and with each clock pulse the pattern gets shifted by one bit position to the

right. With each shift, the bit at the serial input is pushed to the left most position (msb). After how many clock pulses will the content of the shift register become 1010 again ?

- (a) 3 (b) 7 (c) 11 (d) 15

24.

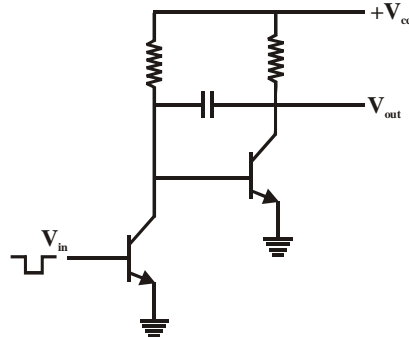

What is the name of the circuit shown above ?

- (a) Miller sweep (b) Bootstrap sweep (c) Schmitt trigger (d) Triangular wave generator

25.

Dual-slope integration type Analog-to-Digital converters provide :

1. Higher speeds compared to all other types of A/D converters.
2. Very good accuracy without putting extreme requirements on component stability.
3. Good rejection of power supply hum.
4. Better resolution compared to all other types of A/D converters for the same number of bits.

- (a) 2 and 3 only (b) 3 and 4 only (c) 4 and 1 only (d) 1, 2, 3 and 4

26.

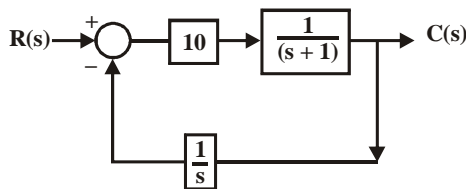

What is the steady-state value of the unit-step response of a closed-loop control system shown in figure ?

- (a) -0.5 (b) 0 (c) 2 (d) ∞

27.

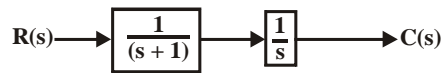

What is the unit impulse response of the system shown in figure for $t \geq 0$?

- (a) $1 + e^{-t}$ (b) $1 - e^{-t}$ (c) e^{-t} (d) $-e^{-t}$

28.

What are the gain and phase angle of a system having the transfer function $G(s) = (s + 1)$ at a frequency of 1 rad/sec ?

- (a) 0.41 and 0° (b) 1.41 and 45° (c) 1.41 and -45° (d) 2.41 and 90°

29.

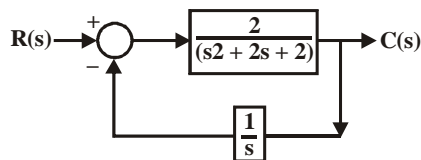

The block diagram of a closed-loop control system is given in figure. What is the type of this system?

- (a) Zero (b) One (c) Two (d) Three

30. Given the differential equation model of a physical system, determine the time constant of the system:

$$40 \frac{dx}{dt} + 2x = f(t)$$

- (a) 10 (b) 20 (c) 1/10 (d) 4
31. Consider a second order all-pole transfer function model, if the desired settling time (5%) is 0.60 sec and the desired damping ratio 0.707, where should the poles be located in s-plane ?

- (a) $-5 \pm j4\sqrt{2}$ (b) $-5 \pm j5$ (c) $-4 \pm j5\sqrt{2}$ (d) $-4 \pm j7$

32. The characteristic equation of a control system is given as :

$$s^4 + 8s^3 + 24s^2 + 32s + K = 0$$

What is the value of K for which the system is unstable ?

- (a) 10 (b) 20 (c) 60 (d) 100
33. Where are the $K = \pm \infty$ points on the root loci of the characteristic equation of the closed loop control system located at ?

- (a) Poles of $G(s)H(s)$ (b) Zeroes of $G(s)H(s)$
 (c) Both Zeroes and Poles of $G(s)H(s)$ (d) Neither at Zeroes nor at Poles of $G(s)H(s)$

34. The characteristic equation of a control system is given as :

$$1 + \frac{K(s+1)}{s(s+4)(s^2+2s+2)} = 0$$

For large values of s, the root loci for $K \geq 0$ are asymptotic to asymptotes, where do the asymptotes intersect on the real do the asymptotes intersect on the real axis /

- (a) $\frac{5}{3}$ (b) $-\frac{2}{3}$ (c) $-\frac{5}{3}$ (d) $\frac{4}{3}$

35. Where are the $K = 0$ points on the root loci of the characteristic equation of the closed loop control system located at ?

- (a) Zeroes of $G(s)H(s)$ (b) Poles of $G(s)H(s)$
 (c) Both Zeroes and Poles of $G(s)H(s)$ (d) Neither at Zeroes nor at Poles of $G(s)H(s)$

36. Given the root locus of a system

$$G(s) = \frac{4K}{(s+1)(s+3)}$$

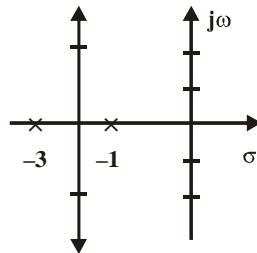

What will be the gain for obtaining the damping ratio 0.707 ?

- (a) 1/4 (b) 5/4 (c) -3/4 (d) 11/4
37. The number of individual loci in a root locus plot is equal to :
- (a) The number of open loop poles (b) The number of open loop zeroes
 (c) The difference of the number of open loop poles and the number of open loop zeroes
 (d) The number of open loop poles or zeroes whichever is greater
38. An electrical system transfer function has a pole at $s = -2$ and a zero at $s = -1$ with system gain 10. For sinusoidal current excitation, voltage response of the system :
- (a) Is zero (b) Is in phase with the current

- (c) Leads the current (d) Lags behind the current

39. For the Bode plot of the system $G(s) = \frac{10}{0.66s^2 + 2.33s + 1}$ the corner frequencies are :
 (a) 0.66 and 0.33 (b) 0.22 and 2.00 (c) 0.30 and 2.33 (d) 0.50 and 3.00
40. If the gain margin of a system in decibels is negative, the system is :
 (a) Stable (b) Marginally stable (c) Unstable
 (d) Could be stable or unstable or marginally stable
41. An electrical network shown in figure. What type of compensator is this ?

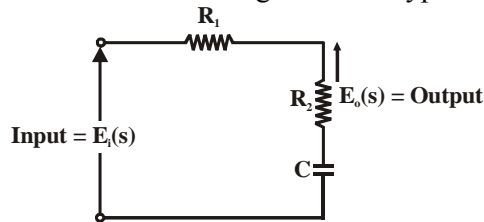

- (a) Phase lead compensator (b) Phase lag compensator
 (c) Lag-lead compensator (d) Neither phase lead nor phase lag compensator
42. The circuit diagram of an electrical network is given in figure. What type of compensator is this ?

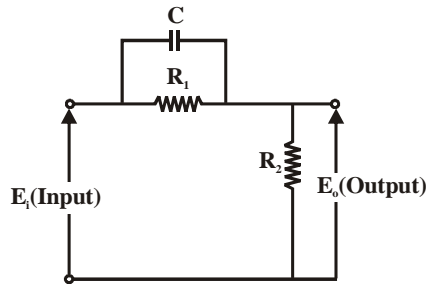

- (a) Phase lag compensator (b) Phase lead compensator
 (c) Lag-lead compensator (d) Neither phase lag nor phase lead compensator
43. What is the transfer function of a phase lag compensator ? The values of α and τ are given as $\alpha > 1$ and $\tau > 0$:

(a) $\frac{1}{\alpha} \frac{\left(s + \frac{1}{\tau}\right)}{\left(s + \frac{1}{\alpha\tau}\right)}$ (b) $\frac{1}{\alpha} \frac{\left(s - \frac{1}{\tau}\right)}{\left(s - \frac{1}{\alpha\tau}\right)}$ (c) $\frac{1}{\alpha} \frac{\left(s + \frac{1}{\tau}\right)}{\left(s - \frac{1}{\alpha\tau}\right)}$ (d) $\frac{1}{\alpha} \frac{\left(s - \frac{1}{\tau}\right)}{\left(s + \frac{1}{\alpha\tau}\right)}$

44. What is the transfer function of a phase lead compensator ? The values of β and τ are given as $\beta < 1$ and $\tau > 0$:

(a) $\frac{\beta(\tau s + 1)}{(\beta\tau s - 1)}$ (b) $\frac{\beta(\beta\tau s + 1)}{(\tau s + 1)}$ (c) $\frac{\beta(\beta\tau s - 1)}{(\tau s + 1)}$ (d) $\frac{\beta(\beta\tau s - 1)}{(\tau s - 1)}$

- 45.

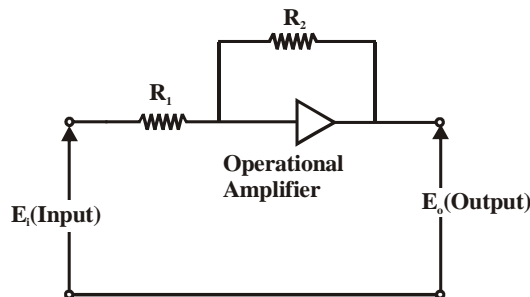

The circuit diagram of a controller is given in figure. What type of controller is this ?

- (a) Derivative (b) Integral (c) Proportional (d) Proportional + Integral

46.

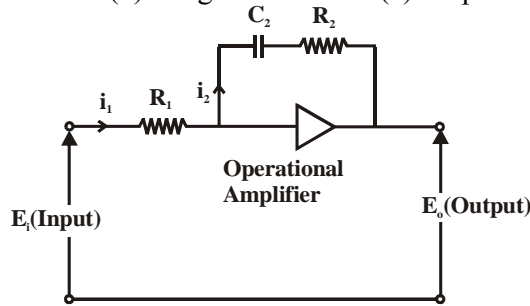

The circuit diagram of a controller is given in figure. What type of controller is this /

- (a) Proportional (b) Proportional + Derivative (c) Integral (d) Proportional + Integral

47.

Discrete source S_1 has 4 equiprobable symbols while discrete source S_2 has 16 equiprobable symbols. When the entropy of these two sources is compared, entropy of :

- (a) S_1 is greater than S_2 (b) S_1 is less than S_2
(c) S_1 is equal to S_2 (d) Depends on rate of symbols/second

48.

What bandwidth is needed for an FM signal that has a peak deviation of ± 3 kHz and handles audio signals from 200 Hz to 5 kHz ?

- (a) 6 kHz (b) 16 kHz (c) 10 kHz (d) 9.6 kHz

49.

The main factor that determines the accuracy of a reconstructed PCM signal is the :

- (a) Signal bandwidth (b) Pulse repetition rate
(c) Pulse amplitude (d) number of bits used for quantization

50.

Match List-I with List-II and select the correct answer using the code given below the lists :

List-I				List-II					
A.	Pilot carrier			1.	Delta modulation				
B.	Tuned circuit			2.	Frequency modulation				
C.	Slope overload			3.	PCM				
D.	A to D converter			4.	Single sideband AM				
Code :	A	B	C	D	A	B	C	D	
(a)	3	2	1	4	(b)	4	2	1	3
(c)	3	1	2	4	(d)	4	1	2	3

51.

Figure shows a block diagram of a system to recover a sampled signal shown as input.

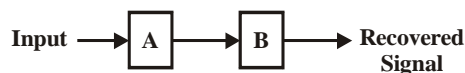

Blocks A and B can be respectively :

- (a) Zero order hold and low pass filter (b) Multiplier and high pass filter
(c) Envelop detector and sampler (d) Tuned circuit and mixer

52.

Which one of the following scheme is a digital modulation technique ?

- (a) Pulse code modulation (b) On-off keying
(c) Pulse width modulation (d) Delta modulation

53.

Consider the following codes :

1. Hamming code 2. Huffman code 3. Shannon-Fano code 4. Convolutional code

Which of these are source codes ?

- (a) 1 and 2 only (b) 2 and 3 only (c) 3 and 4 only (d) 1, 2, 3 and 4

54. PAM signals are constructed by using a low pass filter of pass band slightly greater than base band to avoid aliasing. This avoids distortion :

- (a) True for flat top pulses (b) True if low pass filter has sharp cut off
 (c) Flat top pulses introduce envelope delay
 (d) Flat top pulses introduce amplitude distortion and delay

55. Consider the following advantages of optical fiber-cables :

1. Small diameter
2. Immunity to cross talk and electromagnetic interference
3. Laser and LED modulation methods lend themselves ideally to digital operation

Which of these advantages are correct ?

- (a) 1 and 2 only (b) 2 and 3 only (c) 3 and 1 only (d) 1, 2 and 3

56. Polarization mode dispersion (PMD) is mainly observed in :

- (a) Multiple step-index fiber (b) Single mode fiber
 (c) Multimode graded-index fiber (d) Plastic fiber

57.

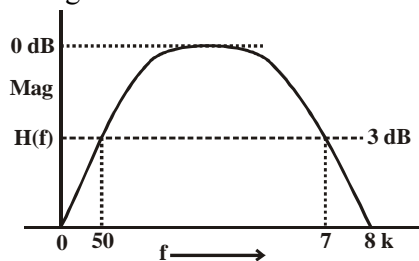

A high fidelity audio amplifier (MPEG) has frequency response as shown in above figure. This response can be improved by which equalizer shown with frequency response $E(f)$ below ?

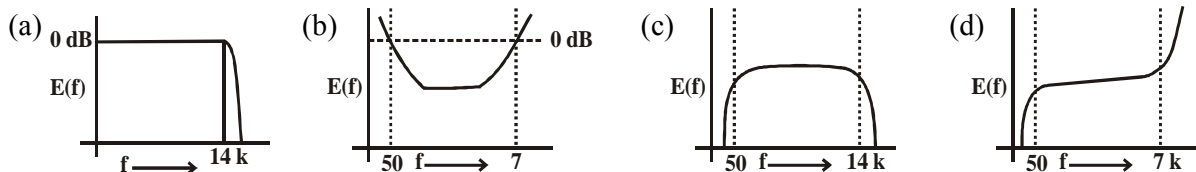

58. Due to the phenomenon of refraction of radio waves in the atmosphere, which of the following effect is observed ?

- (a) Radio horizon distance is more than the optical horizon distance.
 (b) Radio horizon distance is less than the optical horizon distance.
 (c) it all depends upon the weather conditions. Any one of the above choice may be true depending upon type of weather.
 (d) Radio horizon and optical horizon are always same because both radio waves and optical waves are electromagnetic in nature.

59. Mien-wave signals propagating along the curvature of earth is known as :

- (a) Faraday effect (b) Ionosphere reflection (c) Dueting (d) Tropospheric scatter

60. In ship to ship communication, the problem of fading can be overcome by using :

- (a) Frequency diversity (b) Space diversity
 (c) More directional antenna (d) A broad band antenna

61. Microwave frequencies are used for communication with deep space probes primarily because they do not suffer :
- (a) Refraction by ionosphere (b) Attenuation in space
(c) Velocity distortion and phase distortion (d) Fading
62. Consider the following statements about the maximum usable frequency (MUF) for radio communication between two specified points using an ionospheric layer :
1. MUF is equal to critical frequency
 2. MUF is more than the critical frequency
 3. MUF depends upon the height of the ionospheric layer
 4. MUF depends upon the distance between the two points
- Which of these statements are correct ?
- (a) 1, 2, 3 and 4 (b) 2 and 3 only (c) 3 and 4 only (d) 2 and 4 only
63. In a communication system both transmitting and receiving antennas are vertically polarized. On a clear sunny day the power received at the Receiver is 1 mw. On a rainy day due to rain-induced depolarization the plane of polarization of the received wave gets rotated by 60° when it reaches to the receiving antennas. The received power at the receiver shall be :
- (a) 0.5 mw (b) 0.866 mw (c) 1 mw (d) 0.25 mw
64. For communication from satellite to the earth station, microwave frequencies are used because :
- (a) Loss is minimum (b) Noise added to signal is low in this window
(c) These do not get reflected back by ionosphere (d) many channels can be used
65. A Geostationary orbit is chosen for communication satellites because :
- (a) It is stationary at one point in space
(b) With respect to a spot on earth it looks stationary
(c) This orbit provides earth's coverage of more than 50% using a single satellite
(d) The length of 4700 km is convenient for launching
66. A low earth orbit satellite can provide large signal strength at an earth station because :
- (a) Path loss is low (b) These orbits are immune to noise
(c) large solar power can be generated at these orbits
(d) Lower microwave frequencies in s-band can be used
67. If 'r' is the radius of circular orbit then the orbital period of a satellite is directly proportional to :
- (a) $r^{\frac{3}{2}}$ (b) $r^{\frac{1}{3}}$ (c) $r^{\frac{1}{2}}$ (d) $r^{\frac{2}{3}}$
68. IMPATT diode is disadvantageous because of :
- (a) High noise (b) Too many layers
(c) Low efficiency (d) Difficulty in growing intrinsic layer
69. A diode with no junction that is widely used with a cavity resonator to form a microwave oscillator is a/an :
- (a) IMPATT diode (b) TRAPATT diode (c) TUNNEL diode (d) GUNN diode
70. Consider the following time parameters in development of solid state devices :
1. Domain growth time constant
 2. Transit time
 3. Dielectric relaxation time
- In the case of Transferred Electron Devices (TED), which of these are used ?
- (a) 1 and 2 only (b) 2 and 3 only (c) 1 and 3 only (d) 1, 2 and 3

71. Consider the following statements regarding Bunching process in klystron :
1. Bunching occurs in two cavity klystron amplifiers
 2. Bunching occurs in multi cavity Klystron amplifiers
 3. Bunching occurs in reflex Klystron oscillators
- Which of these statements are correct ?
- (a) 1 and 2 only (b) 2 and 3 only (c) 1 and 3 only (d) 1, 2 and 3
72. Consider the following diodes :
1. Gunn diode 2. Schottky diode 3. Crystal diode 4. Tunnel diode
- Which of these can be used as detector diodes ?
- (a) 1 and 2 only (b) 2 and 3 only (c) 3 and 4 only (d) 1, 2, 3 and 4
73. Which one of the following microwave diodes is suitable for very low power oscillations applications only ?
- (a) Tunnel (b) IMPATT (c) VARACTOR (d) GUNN
74. A dominant mode of waveguide is characterized by lowest :
1. Cut-off frequency 2. Cut-off wavelength 3. Attenuation
- (a) 1 only (b) 1 and 3 only (c) 2 and 3 only (d) 1, 2 and 3
75. Consider the following statements in case of a magic Tee :
1. The collinear arms are isolated from each other
 2. One of the collinear arms is isolated from E-arm
 3. One of the collinear arms is isolated from H-arm
 4. E and H arms are isolated from each other
- Which of these statements are correct ?
- (a) 1 and 2 (b) 2 and 3 (c) 3 and 4 (d) 1 and 4
76. A micro-strip line with alumina substrate $\epsilon_r = 9$ has a strip width $w = 3$ mm. Substrate thickness $h = 0.5$ mm. What is the approximate characteristic impedance of the line, assuming TEM wave propagation and negligible fringing field ?
- (a) 50 Ω (b) 26 Ω (c) 21 Ω (d) 10 Ω
77. Strictly speaking, the propagating mode that is excited in a micro-strip transmission line is :
- (a) Only TEM mode (b) Only TE mode (c) Only TM mode (d) Non-TEM mode
78. Maxwell's equations are obeyed by the E.M. waves when these waves are traveling :
- (a) Only in free space (b) Only in free space and water but not in a plasma medium
- (c) Only in free space, water and gases but not in solids
- (d) In all solids, liquids, gases and any other medium given above
79. Which of the following antenna is used as a standard reference for calculating directive gain ?
- (a) Half wave dipole (b) Infinitesimal dipole
- (c) Elementary doublet (d) Isotropic antenna
80. Which of the following antennas exhibit circular polarization ?
- (a) Small circular loop (b) Folded dipole (c) Helical (d) Parabolic dish
81. Match List-I with List-II and select the correct answer using the code given below the lists :
- | | |
|--------------------|---------------------|
| List-I | List-II |
| A. Helical antenna | 1. Fan shaped beams |

- | | |
|------------------------|--------------------------|
| B. Sect-oral horn | 2. Shaped beams |
| C. Phased arrays | 3. Circular polarization |
| D. Parabolic reflector | 4. Pencil beams |
-
- | | | | | | | | |
|----------|---|---|---|-------|---|---|---|
| Code : A | B | C | D | A | B | C | D |
| (a) 3 | 1 | 2 | 4 | (b) 4 | 1 | 2 | 3 |
| (c) 3 | 2 | 1 | 4 | (d) 4 | 2 | 1 | 3 |

82. The following components are used for measuring frequency in a microwave test bench :

- | | |
|---------------------|---|
| 1. Microwave source | 2. Resonant cavity type frequency meter |
| 3. Power meter | 4. Variable attenuator |

What is the correct sequence of connection of these bench components for measurement of frequency ?

- (a) 3, 4, 2 and 1 (b) 1, 2, 4 and 3 (c) 3, 2, 4 and 1 (d) 1, 4, 2 and 3

83. Usually, microwave signals are not used for ionospheric propagation. The reason is :

- (a) Ionospheric layers absorb microwaves tremendously
 (b) Drastic dispersion takes place for microwave signals in ionosphere
 (c) Scattering prevents propagation of microwaves through ionosphere
 (d) Microwaves penetrate through ionosphere layers

84. In microwave communication systems, sometimes, the same frequency is used by separation of signals through vertical and horizontal polarizations. This technique is generally called :

- (a) Steady frequency multiplexing (b) Variable frequency modulation technique
 (c) Frequency reconditioning technique (d) Frequency re-uses technique

85. In a super heterodyne receiver arrange the following components sequentially from input to the output :

- | | | | |
|------------|----------|-----------------|--------------------|
| 1. Antenna | 2. Mixer | 3. IF amplifier | 4. Audio amplifier |
|------------|----------|-----------------|--------------------|

- (a) 1, 2, 3 and 4 (b) 4, 2, 3 and 1 (c) 1, 3, 2 and 4 (d) 4, 3, 2 and 1

86. If 73_x (in base x number system) is equal to 54_y (in base y number system), the possible values of x and y are :

- (a) 8 and 16 (b) 10 and 12 (c) 9 and 13 (d) 8 and 11

87. A bus organized processor consists of 15 registers. The number of selection lines in each multiplexer and in the destination decoder are respectively :

- (a) 2 and 4 (b) 4 and 2 (c) 4 and 4 (d) 4 and 8

88. Sorting is useful for :

- | | |
|---------------------------------|--|
| 1. Report generation | 2. Making searching easier and efficient |
| 3. Responding to queries easily | 4. Minimizing the storage needed |

- (a) 1, 2 and 3 only (b) 1, 3 and 4 only (c) 2, 3 and 4 only (d) 1, 2, 3 and 4

89. Which of the following is/are NOT the functions of assembly-language directions ?

- | | |
|---|---|
| 1. Define system parameters | 2. Assign specific symbolic memory location |
| 3. Control the output of the assembly process | |

- (a) 1 and 2 only (b) 2 and 3 only (c) 1 and 3 only (d) 1, 2 and 3

90. Given below are some applications. Choosing from the options, pick the one that allocates a suitable data structure for implementing these applications :

1. Representation of sparse matrix
 2. Fast access to any item from a set of data
 3. Convert infix expressions to postfix expression
 4. Storing the terms of a long polynomial with arbitrary number of terms
 - (a) Linked list, array listed list and stack
 - (b) Stack, array and stack listed list
 - (c) Array array, tree and stack
 - (d) Linked list, array and stack listed list
91. Which one of the following operators of high level language is used to eliminate the run-time cost of redundant address calculations ?
- (a) Arithmetic
 - (b) Assignment
 - (c) Logical
 - (d) Relational
92. How many passes does a Bubble sort algorithm require for sorting a given list of 'n' items ?
- (a) n^2
 - (b) \sqrt{n}
 - (c) $n + 1$
 - (d) $n - 1$
93. Which of the following instruction processing activity of the CPU can be pipelined ?
1. Instruction encoding
 2. Operand loading
 3. Operand storing
- (a) 1 and 2 only
 - (b) 2 and 3 only
 - (c) 1 and 3 only
 - (d) 1, 2 and 3
94. Which of the following are the problems with using Millions instructions per second (MIPS) as a measure for comparing computer performance ?
1. It does not take into account the capabilities of the instructions.
 2. MIPS can vary inversely with performance.
 3. MIPS varies between programs on the same computer.
- (a) 1 and 2 only
 - (b) 2 and 3 only
 - (c) 1 and 3 only
 - (d) 1, 2 and 3
95. The speed gained by an 'n' segment pipeline executing 'm' tasks is :
- (a) $\frac{(n+m-1)}{mn}$
 - (b) $\frac{mn}{(n+m-1)}$
 - (c) $\frac{n+m}{(mn-1)}$
 - (d) $\frac{n+m}{(mn+1)}$
96. In writing the micro-program, there are two situations in which a field of the micro instruction can be kept blank when it :
1. Controls a functional unit
 2. Causes state to be written
 3. Specifies the control of a multiplexer
- (a) 1 and 2 only
 - (b) 2 and 3 only
 - (c) 1 and 3 only
 - (d) 1, 2 and 3
97. Match List-I with List-II and select the correct answer using the code given below the lists :
- | | |
|--|--|
| <p>List-I</p> <p>A. DMA I/O</p> <p>B. Cache</p> <p>C. Interrupt I/O</p> <p>D. Condition code registers</p> | <p>List-II</p> <p>1. High speed RAM</p> <p>2. Disk</p> <p>3. Printer</p> <p>4. ALU</p> |
|--|--|
- Code : A B C D
- | | | | | | | | | | |
|-----|---|---|---|---|-----|---|---|---|---|
| (a) | 4 | 1 | 3 | 2 | (b) | 2 | 1 | 3 | 4 |
| (c) | 4 | 3 | 1 | 2 | (d) | 2 | 3 | 1 | 4 |
98. If 8085 microprocessor adds 87 H and 79 H, the flags will be :
- (a) S = 1, Z = 0, AC = 0 and Cy = 1
 - (b) S = 0, Z = 0, AC = 1 and Cy = 0
 - (c) S = 1, Z = 1, AC = 1 and Cy = 1
 - (d) S = 0, Z = 1, AC = 1 and Cy = 1
99. Which one of the following control bits of 8086 flag register is used to put the 8086 in single step mode ?
- (a) DF
 - (b) IF
 - (c) TF
 - (d) ZF

100. As compared to 16 bit microprocessor, 8 bit microprocessors are limited in :
- | | | |
|------------------|--------------------------------|-----------------------------|
| 1. Speed | 2. Directly addressable memory | 3. Data handling capability |
| (a) 1 and 2 only | (b) 2 and 3 only | (c) 1 and 3 only |
| | | (d) 1, 2 and 3 |

Directions :—

Each of the next Twenty (20) items consists of two statements, one labeled as the ‘Assertion (A)’ and the other as ‘Reason (R)’. You are to examine these two statements carefully and select the answers to these items using the codes given below :

Codes :

- (a) Both A and R are individually true and R is the correct explanation of A
 (b) Both A and R are individually true but R is NOT the correct explanation of A
 (c) A is true but R is false (d) A is false but R is true
101. Assertion (A) : For producing radiation patterns with predetermined characteristics like beam-width, side-lobe levels etc. phased array antennas are widely used in antenna technology.
 Reason (R) : In phased array antenna system, the resultant radiation pattern is formed by the superposition of electromagnetic waves radiated from various antenna elements which maintain specific, pre-determined phase conditions.
102. Assertion (A) : A memory module presents a specific memory interface to the processor or other unit that references memory.
 Reason (R) : Memory module contains buffer registers for the address and data.
103. Assertion (A) : A unique property of TM_{0n} modes in circular waveguides is rapid decrease in attenuation with increasing frequency.
 Reason (R) : The circular waveguides find application in long low-loss communication.
104. Assertion (A) : A passive satellite only reflects back signals.
 Reason (R) : Communication satellite is a repeater between many transmitting stations and many receiving stations.
105. Assertion (A) : A de-multiplexer cannot be used as a decoder.
 Reason (R) : A de-multiplexer selects one of many outputs, whereas a decoder selects an output corresponding to the coded input.
106. Assertion (A) : A look-ahead carry adder is a fast adder.
 Reason (R) : A parallel carry adder generates sum digits directly from the input digits.
107. Assertion (A) : A tunnel diode has an extremely thin depletion layer.
 Reason (R) : Tunneling phenomenon occurs when a very heavily doped junction is reverse biased.
108. Assertion (A) : The basic group in an FDM system occupies a band 60 kHz to 108 kHz in frequency.
 Reason (R) : The voice channels in FDM are band limited to 4 kHz and carrier frequencies $f_c = 60 + 4 \times n$ kHz are used for 12 channels in the basic group.
109. Assertion (A) : The frequency stability of an oscillator improves as $\frac{d\theta}{d\omega}$ increases, where θ refers to the phase angle of the loop gain.

- Reason (R) : For sustained oscillation to occur in an oscillator circuit, the loop shift should be 0° or $2n\pi$ where n is an integer.
110. Assertion (A) : The power handling capacity of a receiver antenna could be very low compared to identical transmitting antenna.
Reason (R) : A transmitter antenna has to radiate a large power. The receiver antenna will have to deal only with a very small fraction of the radiated power from the transmitter.
111. Assertion (A) : Most high level programming languages include a notion of ‘type’ for expression.
Reason (R) : Type provides implicit context for many operations and it limits the set of operation that may be performed in a semantically valid program.
112. Assertion (A) : The activity reading from or writing into one of the stand alone register and into register file is same.
Reason (R) : The register file has additional control and access overhead compared to the single stand alone register.
113. Assertion (A) : Processor level design is heavily based on the use of prototype structures.
Reason (R) : A prototype design is selected and modified to meet the given performance specifications.
114. Assertion (A) : The low-level control of an I/O device is easier at hardware level.
Reason (R) : It requires managing a set of concurrent events.
115. Assertion (A) : Workstations are often used in engineering applications, especially for interactive design work.
Reason (R) : Work stations with graphics I/O capability have a computational power that is significantly higher than that of personal computers.
116. Assertion (A) : At microwave frequencies, PIN diode can be used as fast switch.
Reason (R) : PIN diode has very high resistance when reverse biased and very low resistances when forward biased.
117. Assertion (A) : Microwave link repeaters are typically about 50 kms apart.
Reason (R) : Curvature effect of Earth makes a limitation for distance between two microwaves repeaters.
118. Assertion (A) : A geostationary orbit is same as a geosynchronous orbit.
Reason (R) : A geostationary orbit does not necessarily lie in equatorial plane.
119. Assertion (A) : The system function $H(s) = \frac{z^3 - 2z^2 + z}{z^2 + \frac{1}{4}z + \frac{1}{8}}$ is not causal.
Reason (R) : If the numerator of $H(s)$ is of lower order than the denominator, the system may be causal.
120. Assertion (A) : Emitter-coupled logic (ECL) provides high speed logic gates.
Reason (R) : ECL prevents adverse effects of diffusion capacitance as it does not operate fully saturated or cut off.